



Great Rivers Greenway

REQUEST FOR BID

For

Replacement of Banners along Leonor K. Sullivan Blvd.

SUBMITTAL DUE DATE: April 9, 2026
1:00 P.M. Prevailing Central Time

SUBMITTAL LOCATION: Great Rivers Greenway
ATTN: Trent Sturms
3745 Foundry Way Suite 253
St. Louis, MO 63110

Questions or information related to this request should be directed to:
Trent Sturms, Operations Supervisor
tsturms@grgstl.org

BACKGROUND

Great Rivers Greenway District (“the District”), is a multi-jurisdictional political subdivision including the City of St. Louis, St. Louis County and St. Charles County. The primary purpose of the District is to improve the quality of life throughout the St. Louis region by developing a public system of interconnected greenways, trails and parks.

Great Rivers Greenway is seeking bids for replacement and installation of multi-colored fabric banners for light poles along Leonor K. Sullivan (LKS) Boulevard. The pole banners are placed on light poles along the Mississippi Greenway between Chouteau Avenue on the South and Biddle Street on the North. There are two styles of light poles, 90 degree straight light poles; and 45 degree sloped light poles. Pole banner frames and brackets are custom fabricated and mounted to existing light poles. Banners are color blocked triangles mounted to frames via grommets and cordage. Banners are mounted two per pole, 1 each side (north and south). The banners alternate in color from red/yellow to blue/yellow. The banner frames are located approximately 20 feet above grade.

Issue Date: M a r c h 27 , 2026



SPECIFICATIONS

Furnish all materials and labor to fabricate and install the following:

- Qty. (40) Red/Yellow Flag Banner for 90° Pole
- Qty. (15) Red/Yellow Flag Banner for 45° Pole
- Qty. (40) Blue/Yellow Flag Banner for 90° Pole
- Qty. (15) Blue/Yellow Flag Banner for 45° Pole
- Qty. (5) Banner frames and brackets for 45° Pole
- Qty. (10) Banner frames and brackets for 90° Pole

Banners are to be Sunbrella fabric welded & sewn with (37) SS grommets each. Banners mounted into frames with 5/16" solid braid halyard and rope clamps. See Exhibit A for frame drawings.

DELIVERY

Banners and frames are to be delivered to and installed on existing poles at Leonor K. Sullivan Blvd. along the Saint Louis Riverfront. Overages are to be delivered to Great Rivers Greenway at 1100 Ohio Ave., St. Louis, MO 63104.

INSTRUCTIONS FOR SUBMITTING A BID

- i. The name and address of the vendor.
- ii. Pricing of equipment/material per specifications.
- iii. Date of availability.

The vendor shall complete the attached Bid form (Form GRG 1) Blank forms shall not be accepted, and the bid will not be evaluated. Questions regarding the specifications or bid process should be submitted for review and response by The District as early as possible in the bidding process.

The Contract Award will be based on the lowest and best bid meeting specifications.

Questions regarding this bid are to be sent via email no later than April 1, 2026 at 5:00 p.m. prevailing central time to Trent Sturms, Operations Supervisor, tsturms@grgstl.org Responses shall be issued no later than April 3, 2026 to all known plan holders who provided information when downloading the bid packet from the District website.



Bid Submittal

Bid due date is April 9, 2026 at 1:00 P.M. prevailing central time. No late submittals will be accepted.

Deliver one (1) sealed hard copy submittal via mail to the address below. The District invites bids on the appropriate form attached hereto, all blanks of which must be filled. Bids will be received in the office of the District no later than the time and date indicated in the "Invitation to Bid." Any bid received after above-stated closing time will not be accepted. It is the responsibility of the bidding party to ensure the bid has arrived at the District office by the deadline. Bids delivered in person or via mail must be submitted in a sealed opaque envelope. Bid envelope shall be marked in upper left-hand corner with the name of firm submitting the bid, and in lower left-hand corner envelope shall be marked "Replacement of Banners along Leonor K. Sullivan Blvd."

Bids to be addressed to:

Trent Sturms, Operations Supervisor
Great Rivers Greenway
3745 Foundry Way suite 253
St. Louis, MO 63110

All bids received on time by the District will be publicly opened from the GRG Missouri Room.

Bids shall be signed in ink. Prices must be expressed in words and figures. Any Bid which fails to name a price in both figures and writing may be deemed informal and may be rejected. In case of any discrepancy between the price written in the Bid and that given in figures, the lower price will be considered as the Bid.

Erasures or other changes in a Bid must be explained or noted over signature of Bidder. Bids containing any conditions, omissions, unexplained erasures or alterations, or irregularities of any kind may be rejected as incomplete. GRG reserves the right to reject any and all Bids submitted.

Delivery: to be delivered to the Great Rivers Greenway Shop at 1100 Ohio Street, Saint Louis, MO 63104

Bid results will be posted on the District website following bid opening. Bidders will be notified by email once a contractor is selected for the project.



MINORITY AND WOMEN BUSINESS ENTERPRISE POLICIES

It is the policy of the District that minority and women-owned businesses shall have the maximum opportunity to participate in the performances of contracts utilizing District funds. While not a requirement, the District has established Minority and Women Business Enterprise goals of 25/5% i.e. 25% of the total contract amount to be awarded to Minority Business Enterprises (MBE) and 5% of the total contract amount to be awarded to Women Business Enterprise (WBE). It is the prospective firm's responsibility to make a sufficient portion of the work available to sub-contractors to meet the goal, consistent with the availability and capacities of MBE and WBE firms. MBE/WBE firms, if included in the submittal, either as General Contractor or Sub-Contractors, must be certified by one or more of the follow agencies on or before the date of the submission of qualifications:

- Missouri Division of Purchasing and Materials Management
- City of St. Louis: Disadvantage Business Enterprise Program
- St. Louis Minority Business Council

GENERAL PROVISIONS

Any contract awarded as a result of this Request for Bid will be awarded without discrimination on race, color, religion, age, sex, sexual orientation, or national origin.

The District reserves the right, at its sole discretion, to 1) reject any or all submittals when, in its opinion, it is determined to be in the public interest to do so, 2) waive minor informalities of a submittal, 3) cancel, revise, or extend this solicitation, 4) request additional information which the District deems necessary.

This Request for Bids does not obligate the District to pay any costs incurred by any respondent in the submission of a bid or in making necessary studies or design for the preparation thereof, or for procuring or contracting for the services to be furnished under this request for bids. The District will give preference to firms located in the District (St. Louis City, St. Louis County and/or St. Charles County) and secondly, in the State of Missouri, when other considerations are equal.

Prospective consultants shall assure the District that they will comply with The Americans with Disabilities Act of 1990 and Revised ADA Regulations Implementing Title II and Title III, which prohibit discrimination on the basis of disability, as well as all applicable regulations and guidelines issued pursuant to the ADA (42 U.S.C. 12101 et seq.) and 2010 ADA standards for Accessible Design.



Any contract awarded pursuant to this Request for Bid shall require the consultant to execute and deliver to the District an affidavit confirming the consultant's enrollment in the E-Verify federal work authorization program with respect to its employees, in compliance with Section 285.530 R.S.Mo. as well as a copy of the consultant's E-Verify MOU. Consultants shall not be required to execute the affidavit and supply an E-Verify MOU copy if either (i) the compensation to be paid under the contract is \$5,000 or less, or (ii) the consultant does not have any employees (though an affidavit attesting that the consultant has no employees will still be required).

Any contracts awarded pursuant to this Request for Proposal will require the contracting company to execute and deliver to the District an affidavit certifying that the company and any company affiliated with it, does not boycott Israel and will not boycott Israel during the term of the contract. This paragraph shall not apply if the compensation to be awarded under the contract is less than \$100,000 or if the company has less than 10 employees (though an affidavit attesting that the company has less than 10 employees will still be required). In this paragraph, the terms "company" and "boycott Israel" shall have the meanings described in Section 34.600 of the Missouri Revised Statutes.



GRG FORM 1

To: The Great Rivers Greenway District

I, _____, representing
Print Name

Company Name **Phone Number**

Address **City** **State** **ZIP**

Submits the following bid for this project with exceptions as noted:

Bid Price (including delivery charges) \$ _____

_____ **dollars**

Availability Date: _____

Signed, _____

Print name

Exhibit A





BANNER 2- 45 DEGREE

MATERIAL: 3/4" DIA SS SCHEDULE 40 PIPE

3/16" 304 STAINLESS STEEL

1/4" SS PLATE- TABS

FINISH: BEAD BLAST

QTY: 1

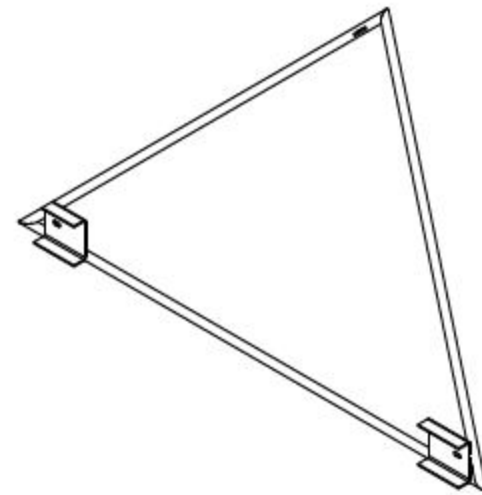
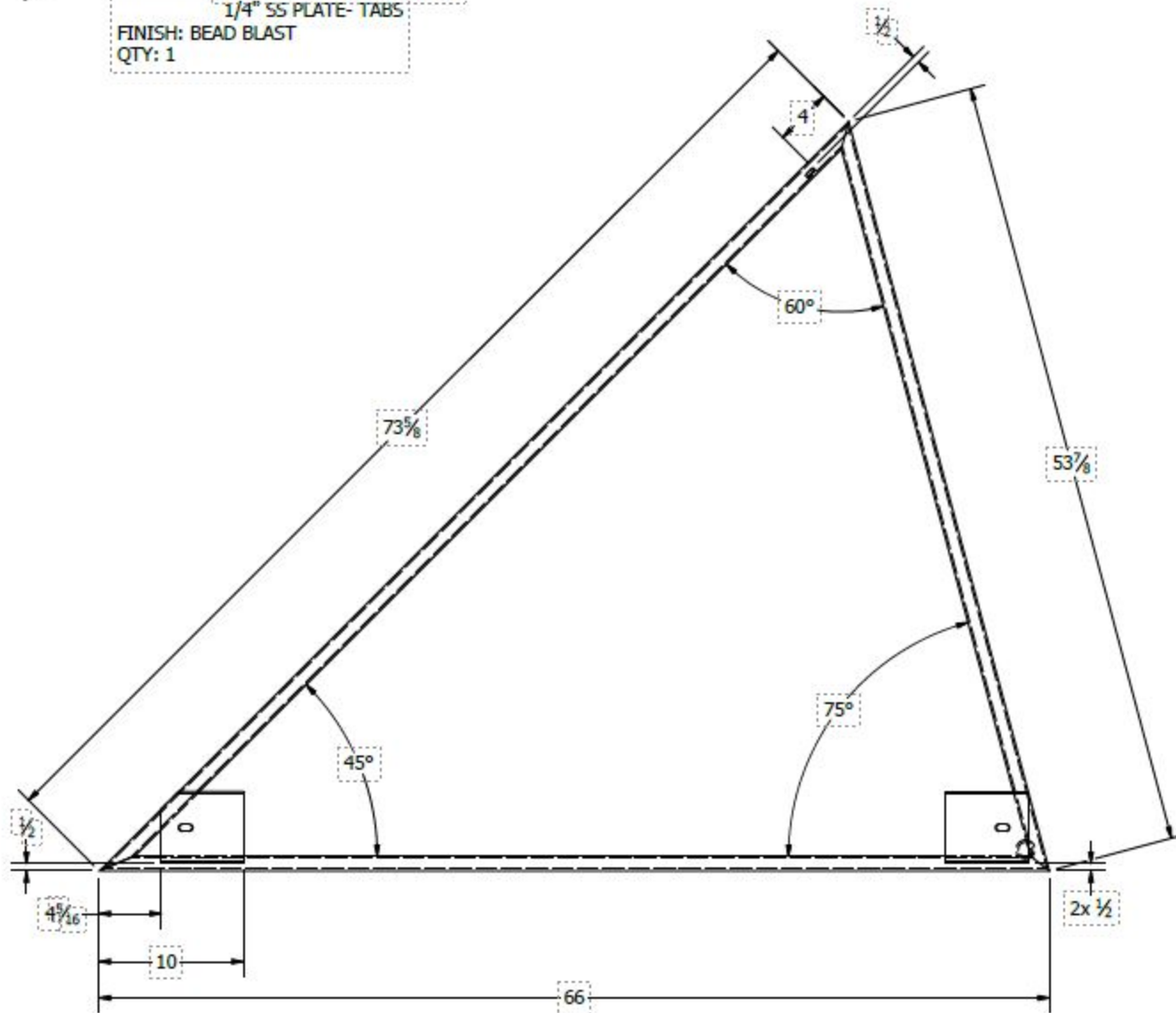

RING DETAIL-REAR VIEW

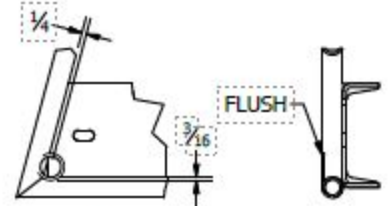

DETAIL E
SCALE 0.16 : 1

BANNER 2- CUT LIST

2A
MATERIAL: 3/4 STAINLESS STEEL
SCHEDULE 40 PIPE
QTY: 1



2B
MATERIAL: 3/4 STAINLESS STEEL
SCHEDULE 40 PIPE
QTY: 1

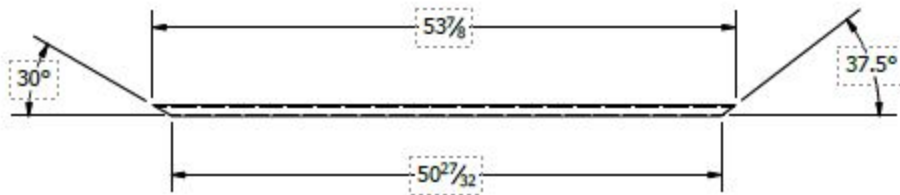

2C
MATERIAL: 3/4 STAINLESS STEEL
SCHEDULE 40 PIPE
QTY: 1

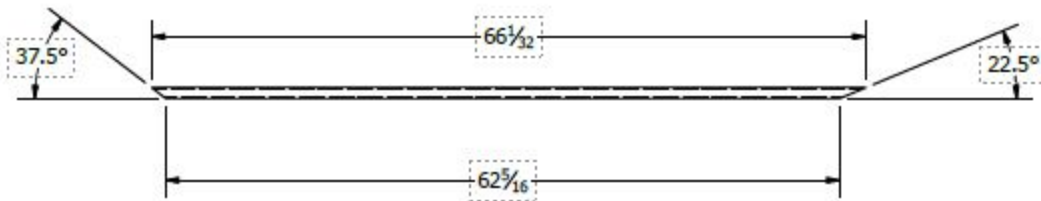

CHANNEL 2A

MATERIAL: 3/16 304 STAINLESS STEEL
QTY: 1

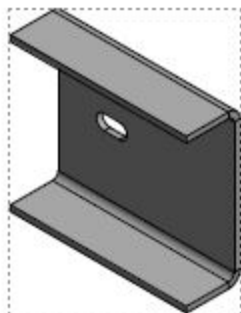
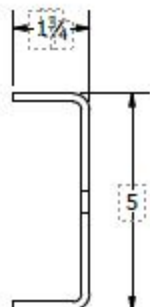
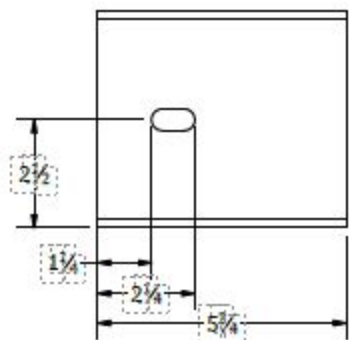

CHANNEL 2B

MATERIAL: 3/16 304 STAINLESS STEEL
QTY: 1

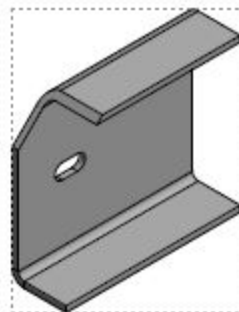
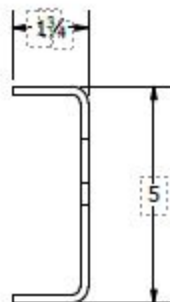
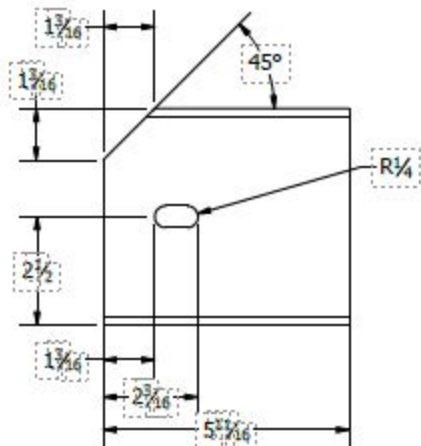

TAB

MATERIAL: 1/4" SS PLATE
QTY: 1

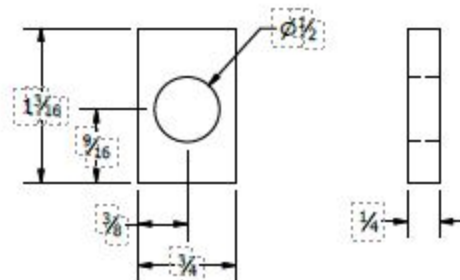

RING

QTY: 1

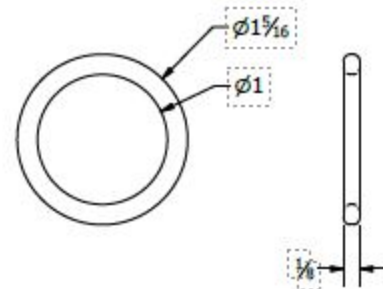



BANNER 1- 90 DEGREE

MATERIAL: 3/4" 304 SS SCHEDULE 40 PIPE
C 5x6.70 SS CHANNEL
1/4" SS PLATE- TABS

FINISH: BEAD BLAST
QTY: 3

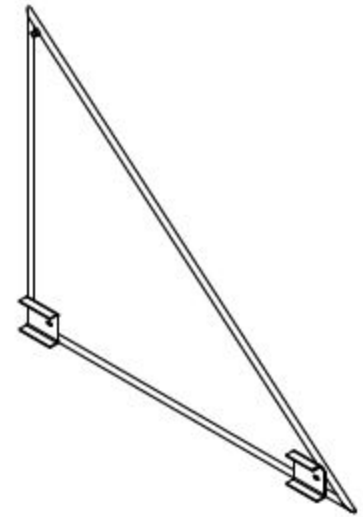
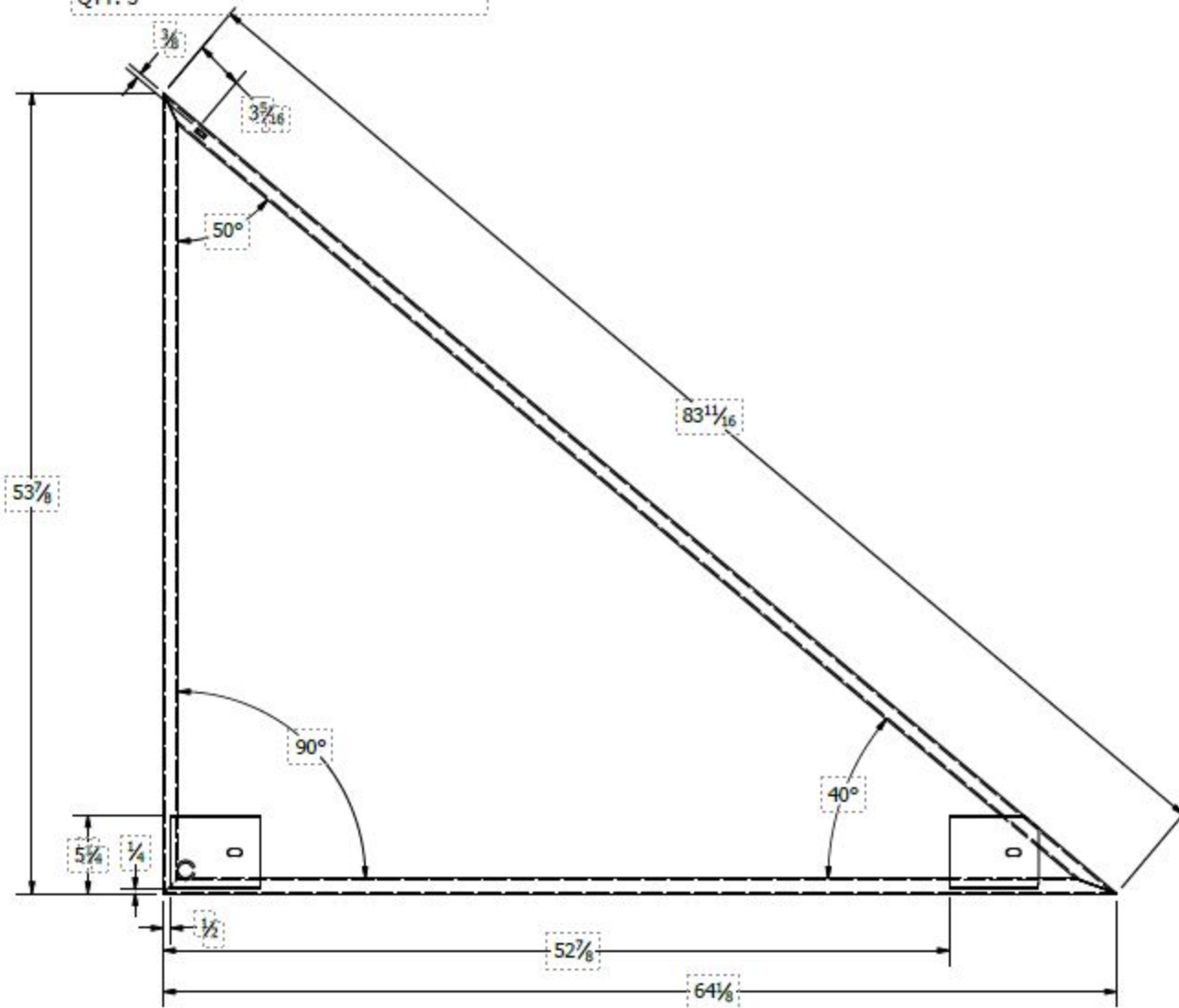

RING DETAIL-REAR VIEW

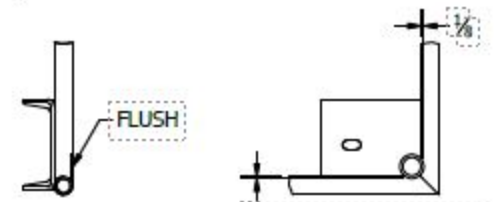

DETAIL F
SCALE 0.14 : 1



BANNER 1- CUT LIST



1A
MATERIAL: 3/4 STAINLESS STEEL
SCHEDULE 40 PIPE
QTY: 3



1B
MATERIAL: 3/4 STAINLESS STEEL
SCHEDULE 40 PIPE
QTY: 3



1C
MATERIAL: 3/4 STAINLESS STEEL
SCHEDULE 40 PIPE
QTY: 3

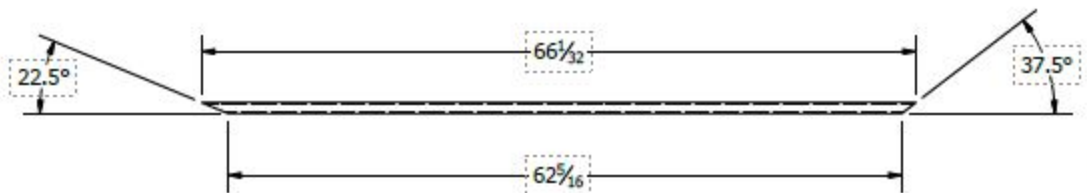

CHANNEL 1A
 MATERIAL: 3/16 304 STAINLESS STEEL
 QTY: 3

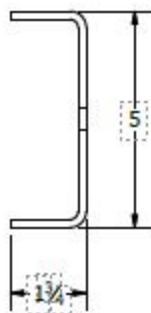
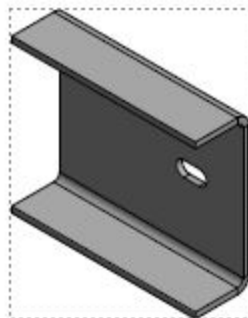
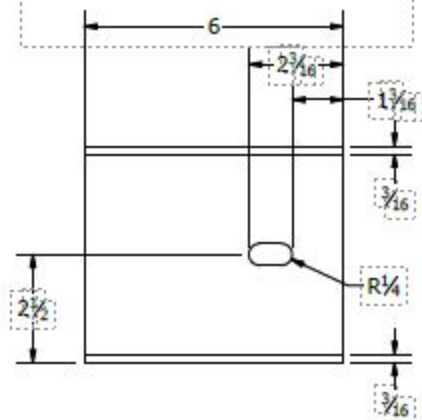

CHANNEL 1B
 MATERIAL: 3/16 304 STAINLESS STEEL
 QTY: 3

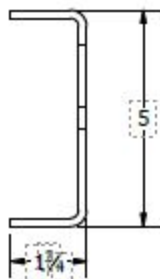
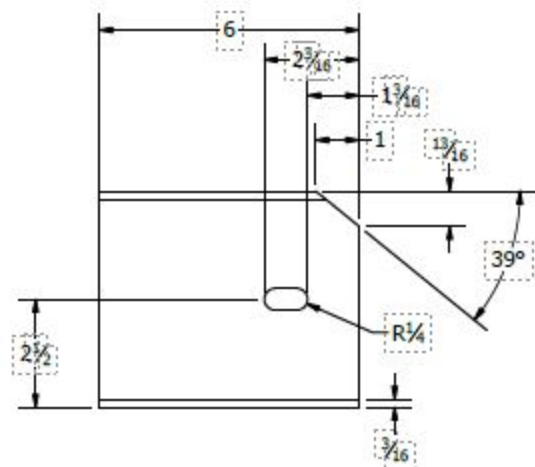

TAB
 MATERIAL: 1/4" SS PLATE
 QTY: 3

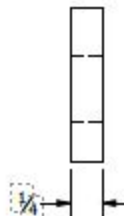
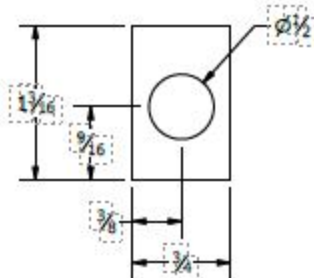

RING
 QTY: 3

