

NOTES:

- 1.) Post size depends on fence height and wind loads. See MONTAGE PLUS™ specifications for post sizing chart.
- 2.) Forth rail optional.
- 3.) 7' & 8' Heights will require a 14ga Picket and 14ga Post.

RAKING DIRECTIONAL ARROW
 Welded panel can be raked 30" over 8' with arrow pointing down grade.

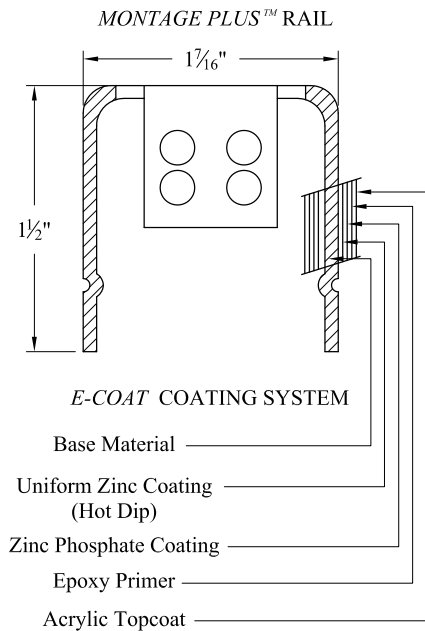

PROFUSION™ WELDING PROCESS

No exposed welds,
 Good Neighbor profile - Same appearance on both sides

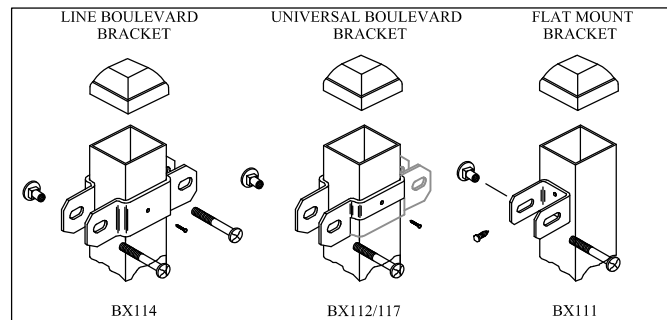
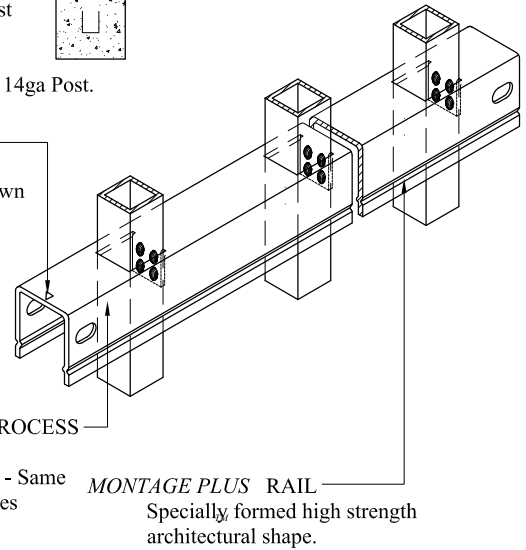

COMMERCIAL STRENGTH WELDED STEEL PANEL
PRE-ASSEMBLED

Values shown are nominal and not to be used for installation purposes. See product specification for installation requirements.

1RMISO7-8

Title: **MONTAGE COMMERCIAL MAJESTIC 3/4-RAIL**

DR: NJB SH . 1 of 1 SCALE: DO NOT SCALE

CK: BS Date 09/21/11 REV: d



AMERISTAR®

1555 N. Mingo
 Tulsa, OK 74116
 1-888-333-3422
 www.ameristarfence.com